

TNC Straight Cable Plug

TNC1C50-R240A/144

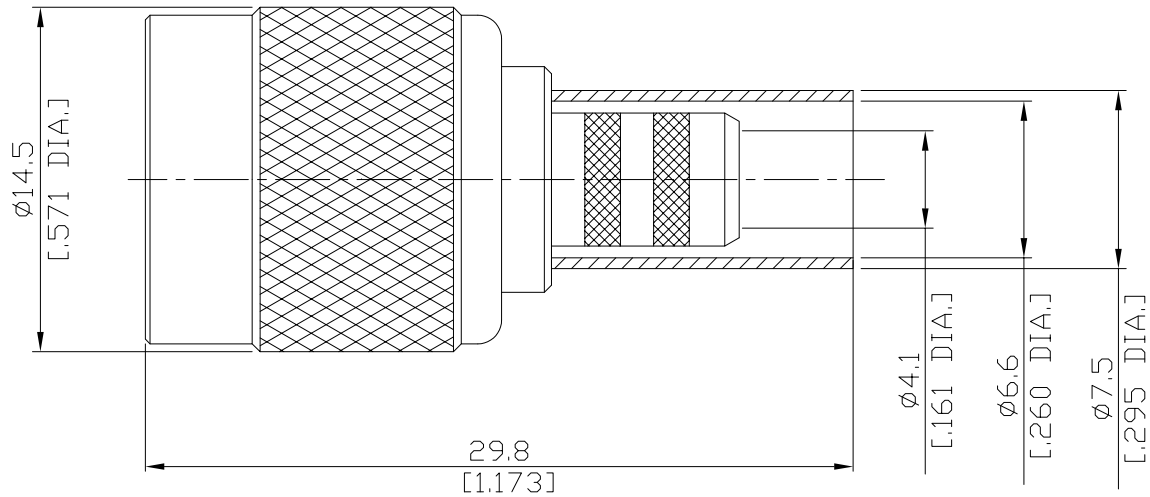

All dimensions are in mm [inch]

Tolerances according to DIN ISO 2768-mH

**Interface**

According to IEC 60169-17; MIL-C-39012; MIL-STD-348A/313

**Electrical Data**

Impedance 50 Ω  
Frequency DC to 6 GHz

- Limitations are possible due to the used cable type and manufacturing process -

**Mechanical Data**

Coupling mechanisms Screw-lock  
Centre contact Soldered or Crimped  
Cable entry Crimped

**Environmental Data**

Temperature range -65°C to +165°C  
RoHS compliant

**Material And Plating**

Connector parts	Material	Plating
Centre contact	Brass	Gold plating(Nickel underplated)
Body	Brass	Copper-Tin-Zinc Alloy
Insulator	PTFE	
Gasket	Silicone Rubber	
Coupling nut	Brass	Copper-Tin-Zinc Alloy
Crimp ferrules	Brass	Copper-Tin-Zinc Alloy

**Suitable Cables**

LMR 240, BELDEN H155, RNL-240

**Packing**

Single or 100

TNC Straight Cable Plug

TNC1C50-R240A/144

**Recommended Cable Stripping Dimensions**

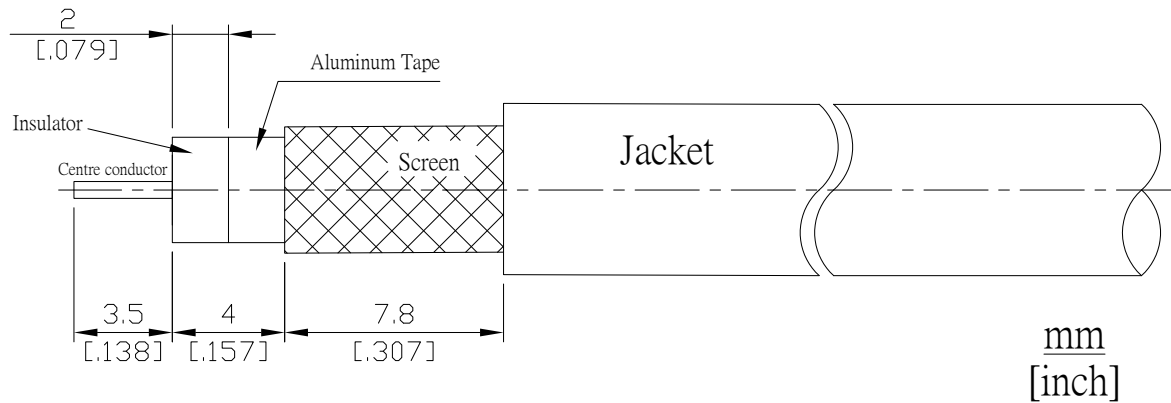

**Crimp Dimensions [HEX]**

Crimp ferrule	6.48mm [.255 inch]
Centre contact	1.73mm [.068 inch]