

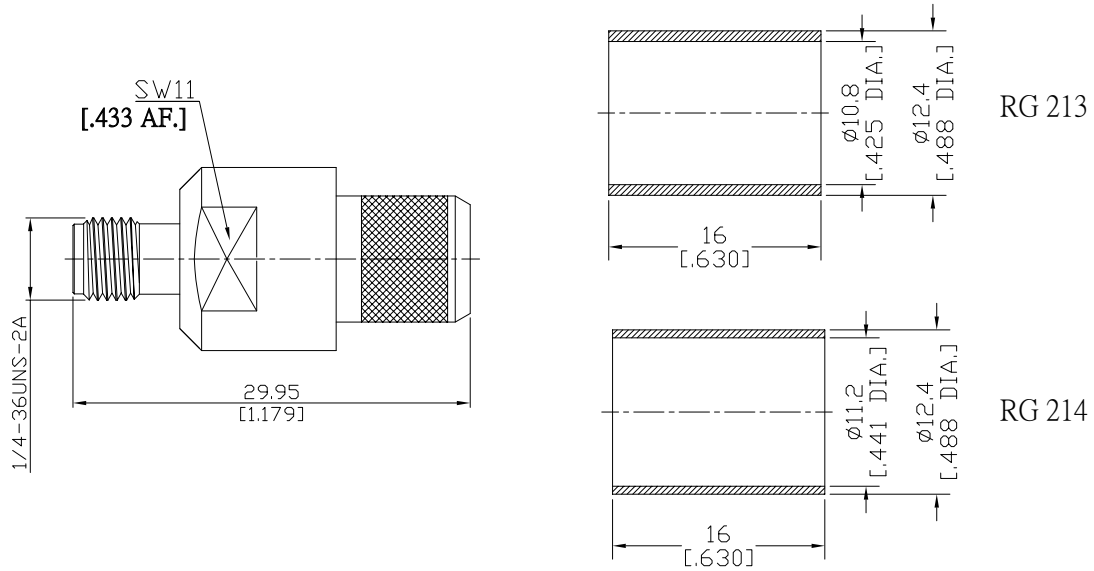

SMA Jack (Female) Cable Connector

SMA2C50-G213-214AA/94



All dimensions are in mm [inch]
Tolerances according to DIN ISO 2768-mH

Interface

According to IEC 60169-15; MIL-STD-348A/310

Electrical Data

Impedance 50 Ω
Frequency DC to 6 GHz
VSWR (Return loss) ≤ 1.20 (≥ 20.83 dB)

- Limitations are possible due to the used cable type and manufacturing method -

Mechanical Data

Coupling mechanisms Screw-lock
Centre contact Solder or Crimp
Cable entry Crimp

Environmental Data

Temperature range -65°C to +165°C
RoHS compliant
REACH compliant

Material And Plating

Connector parts	Material	Plating
Centre contact	Beryllium Copper	Gold plating(Nickel underplated)
Body	Brass	Copper-Tin-Zinc Alloy
Insulator	PTFE	

Suitable Cables

RG-213, RG-214, RG-393

Packing

Single or 100

Cable Stripping Dimensions

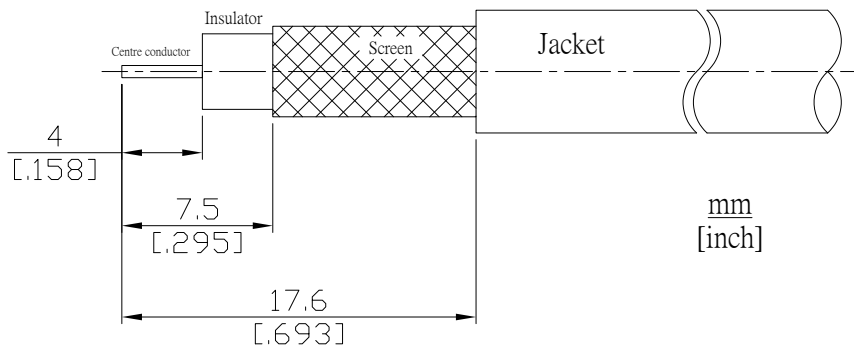

Crimp Dimensions [HEX]

Crimp ferrule	10.90mm [.429 inch]
Centre contact	2.54mm [.100 inch]