

Torque Wrench

RN-RTW-ECO-22-44.3

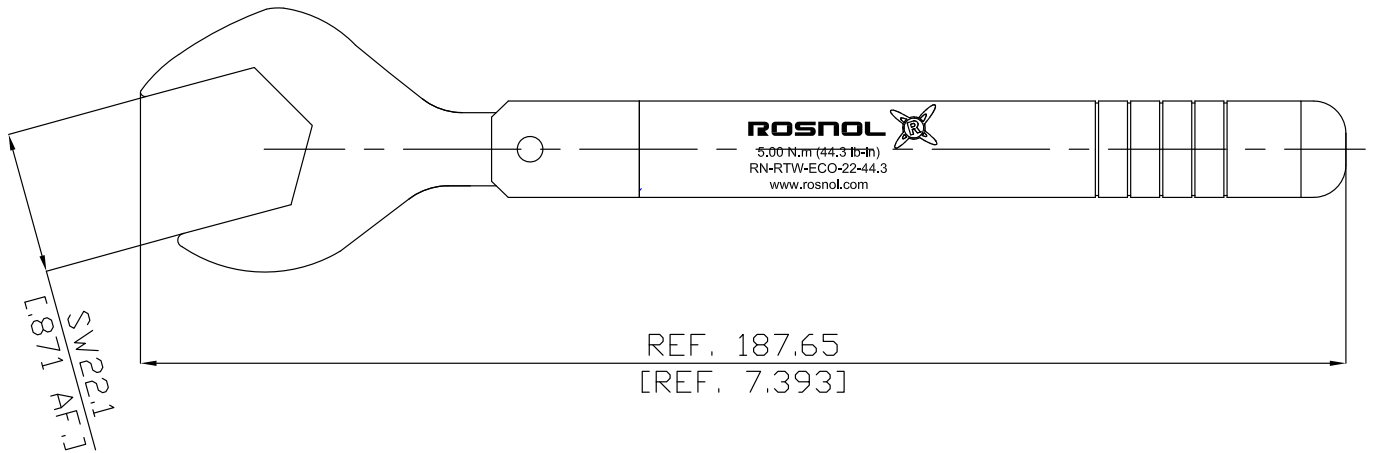

All dimensions are in mm [inch]

Suitable Vector Network Analyzer (VNA)

Keysight, Anritsu

Suitable connector

N/A

Material And Plating

Tooling parts	Material	Plating
Spanner	Tool Steel	Nickel
Handle	Aluminum	

Mechanical data

Width across flats	22.1 mm [.870 inch]
Torque setting	44.3 lb-in \pm 0.5lb-in [5.0 Nm \pm 0.06 Nm]

Packing

Single