

N Straight Cable Plug

N1C50-G058A/133

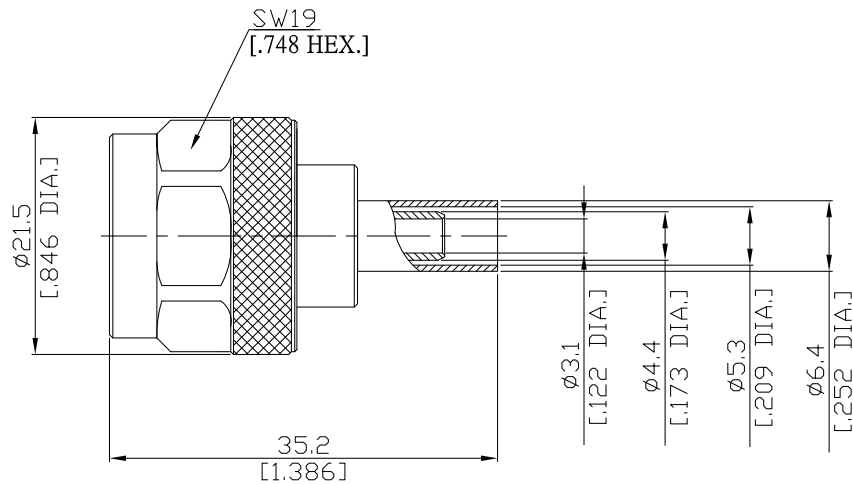

All dimensions are in mm [inch]

Tolerances according to DIN ISO 2768-mH

Interface

According to IEC 61169-16; MIL-C-39012; MIL-STD-348A/304; CECC 22210

Electrical Data

Impedance 50 Ω
 Frequency DC to 6 GHz
 VSWR (Return Loss) ≤ 1.15 (≥ 23.1 dB)
 Insertion Loss ≤ 0.05
 Working voltage (at sea level) 1400 V rms

- Limitations are possible due to the used cable type and manufacturing process -

Mechanical Data

Coupling mechanisms Screw-lock
 Centre contact Soldered or Crimped
 Cable entry Crimped

Environmental Data

Temperature range -65°C to +165°C
 RoHS compliant

Material And Plating

Connector parts	Material	Plating
Centre contact	Brass	Gold plating(Nickel underplated)
Body	Brass	Nickel
Insulator	PTFE	
Gasket	Silicone Rubber	
Coupling nut	Brass	Nickel
Crimp ferrules	Brass	Nickel

Suitable Cables

RG 58, RG 58A, RG 58C, RG 141, RG 303, BELDEN 7806A, BELDEN 9907, LMR 195

Packing

Single, 5-pack, or 100

N Straight Cable Plug

N1C50-G058A/133

Recommended Cable Stripping Dimensions

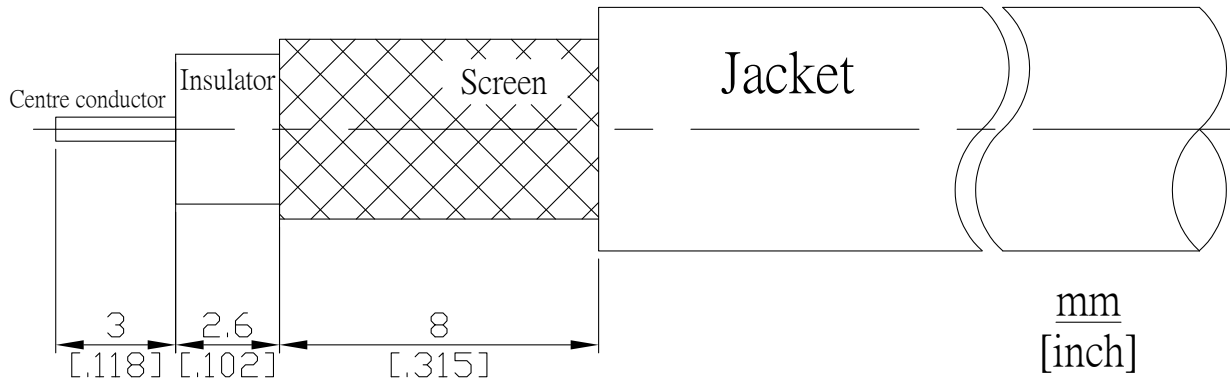

Crimp Dimensions [HEX]

Crimp ferrule	5.41 mm [.213 inch]
Centre contact	1.73 mm [.068 inch]