

REVISION			
REV.	DESCRIPTION	DATE	APPROVED
-	INITIAL RELEASE	2015/07/13	

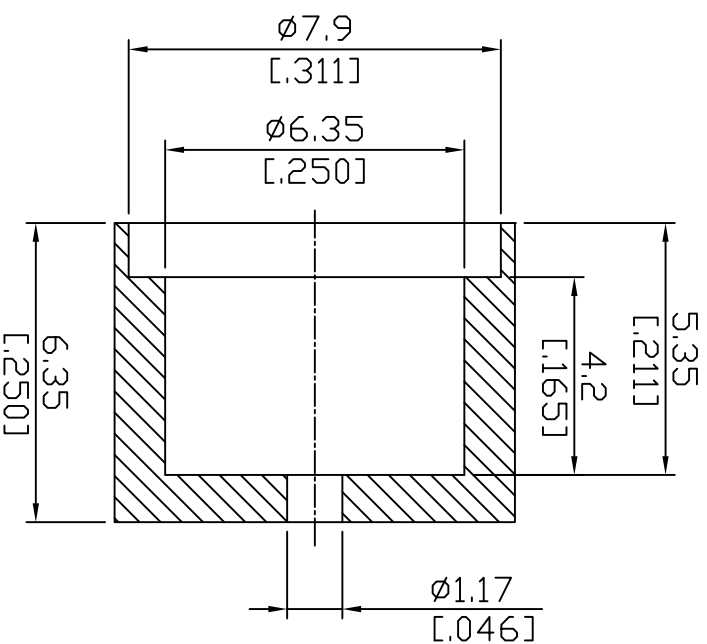

## CUSTOMER OUTLINE DRAWING

**NOTICE** - These drawings, specifications, or other data are, and remain the property of Rosnol corp, must be returned upon request; and are confidential and not to be disclosed to any person other than those to whom they are given by Rosnol Corp. the finishing of these drawings, specifications, or other data by Rosnol Corp., or to any other person to anyone for any purpose is not to be regarded by implication or otherwise in any manner licensing, granting rights to permitting such holder or any other person to manufacture, use or sell any product, process or design, patented or otherwise, that may in any way be related to or disclosed by said drawings, specifications, or other data.

ALL DIMENSIONS ARE IN mm (inch)  
 UNLESS OTHERWISE SPECIFIED,  
 DIMENSIONS ARE AND  
 TOLERANCES ARE  
 < 0.5mm =  $\pm 0.05$ mm  
 0.5 ~ 6mm =  $\pm 0.1$ mm  
 6~30mm =  $\pm 0.2$ mm  
 30~120mm =  $\pm 0.3$ mm  
 Angles =  $\pm 1^\circ$

DRAWN	DATE	DRAWN	DATE	SCALE	UNIT	REV
ENGINEER	DATE	APPROVED	DATE	6 / 1	mm [inch]	-



**Rosnol**  
 RF/Microwave Technology  
 www.rosnol.com  
 info@rosnol.com

DES.  
 Mounting Dimension

DRAWING NO.  
 MD 46