

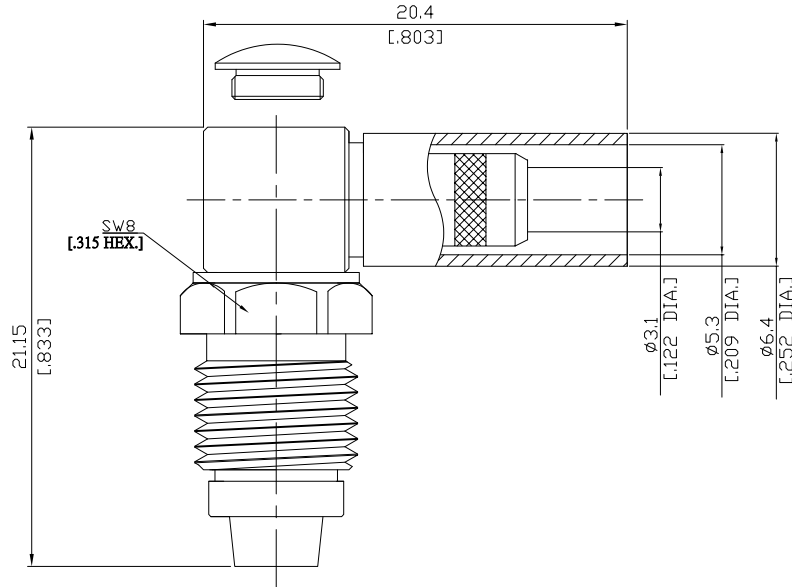

FME Right-Angle Cable Jack

FME2C59-G058A/H3



All dimensions are in mm [inch]  
Tolerances according to DIN ISO 2768-mH

**Interface**

According to N/A

**Electrical Data**

Impedance 50 Ω  
Frequency DC to 2.5 GHz

- Limitations are possible due to the used cable type and manufacturing process -

**Mechanical Data**

Coupling mechanisms Screw-lock  
Centre contact Soldered  
Cable entry Crimped

**Environmental Data**

Temperature range -65°C to +165°C  
RoHS compliant

**Material And Plating**

Connector parts	Material	Plating
Centre contact	Brass	Gold plating(Nickel underplated)
Body	Brass	Nickel
Insulator	PTFE	
Crimp ferrules	Brass	Nickel

**Suitable Cables**

RG-58C, RG-303, LMR 195, RNL-195

**Packing**

Single, 5-pack, or 100

FME Right-Angle Cable Jack

FME2C59-G058A/H3

Recommended Cable Stripping Dimensions

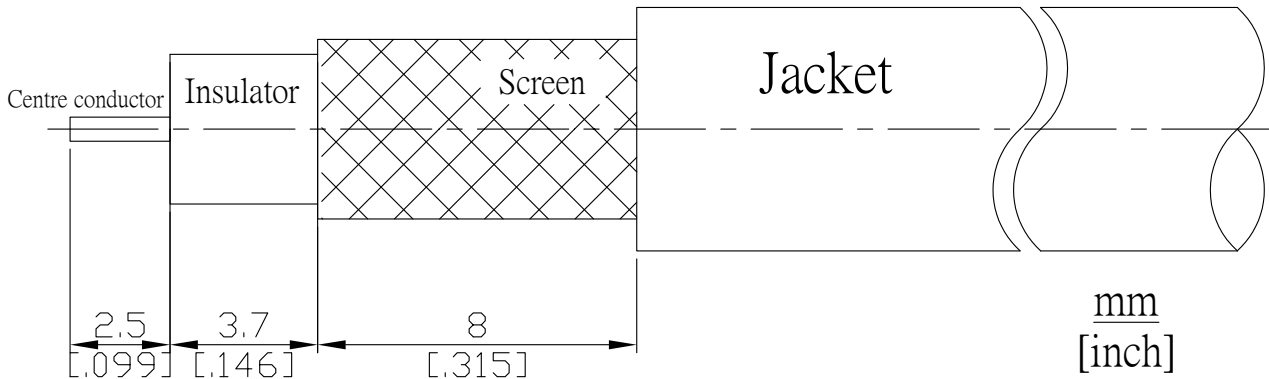

Crimp Dimensions [HEX]

Crimp ferrule 5.41 mm [.213 inch]