

FME Straight Cable Plug

FME2C50-R240B/H4

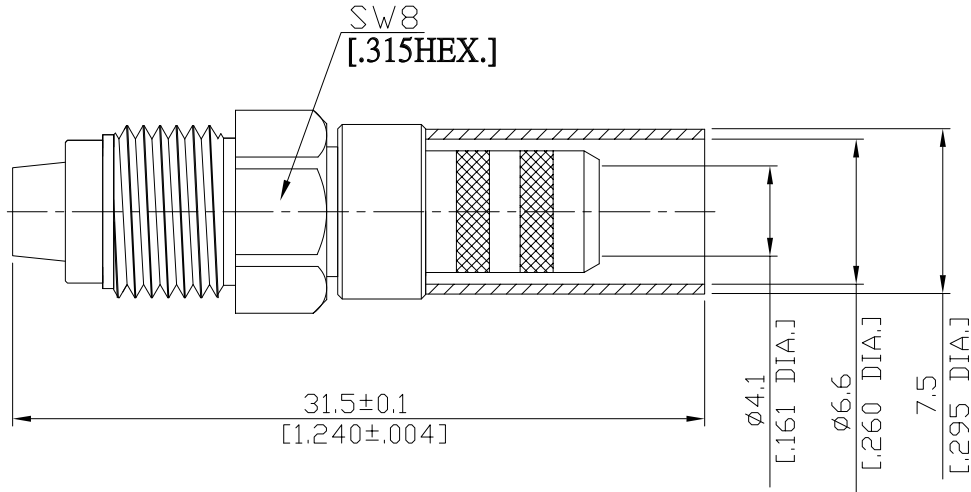

All dimensions are in mm [inch]
Tolerances according to DIN ISO 2768-mH

Interface

According to N/A

Electrical Data

Impedance 50 Ω
Frequency DC to 2.5 GHz

- Limitations are possible due to the used cable type and manufacturing process -

Mechanical Data

Coupling mechanisms Screw-lock
Centre contact Soldered or Crimped
Cable entry Crimped

Environmental Data

Temperature range -65°C to +165°C
RoHS compliant

Material And Plating

Connector parts	Material	Plating
Centre contact	Phosphor Bronze	Gold plating(Nickel underplated)
Body	Brass	Copper-Tin-Zinc Alloy
Insulator	PTFE	
Crimp ferrule	Brass	Copper-Tin-Zinc Alloy

Suitable Cables

LMR 240, BELDEN H155, RNL-240, BELDEN 7808A, BELDEN 9258

Packing

Single or 100

FME Straight Cable Plug

FME2C50-R240B/H4

Recommended Cable Stripping Dimensions

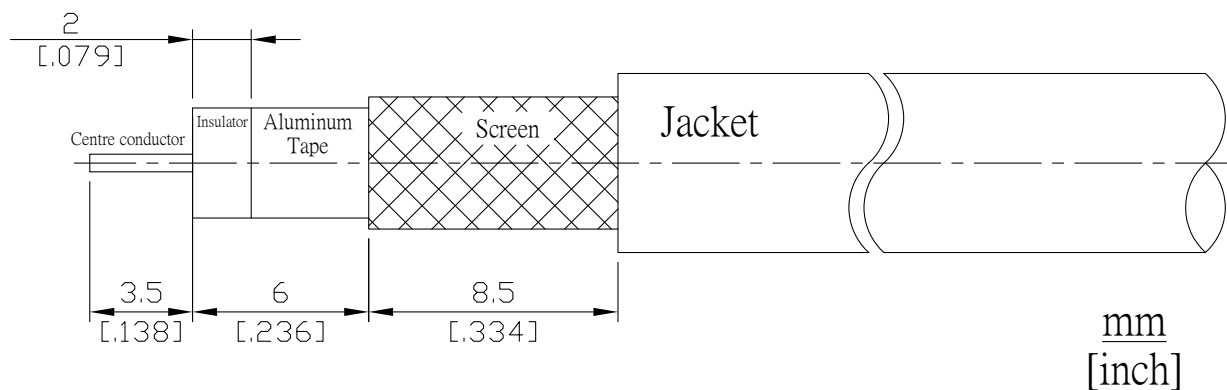

Crimp Dimensions [HEX]

Crimp ferrule	6.48mm [.255 inch]
Centre contact	1.73mm [.068 inch]